

Sun Hydraulics Cavity Tools – Next Generation

Tangential coolant outlets
for better chip removal

Guide pads for the optimal
positioning of the bore

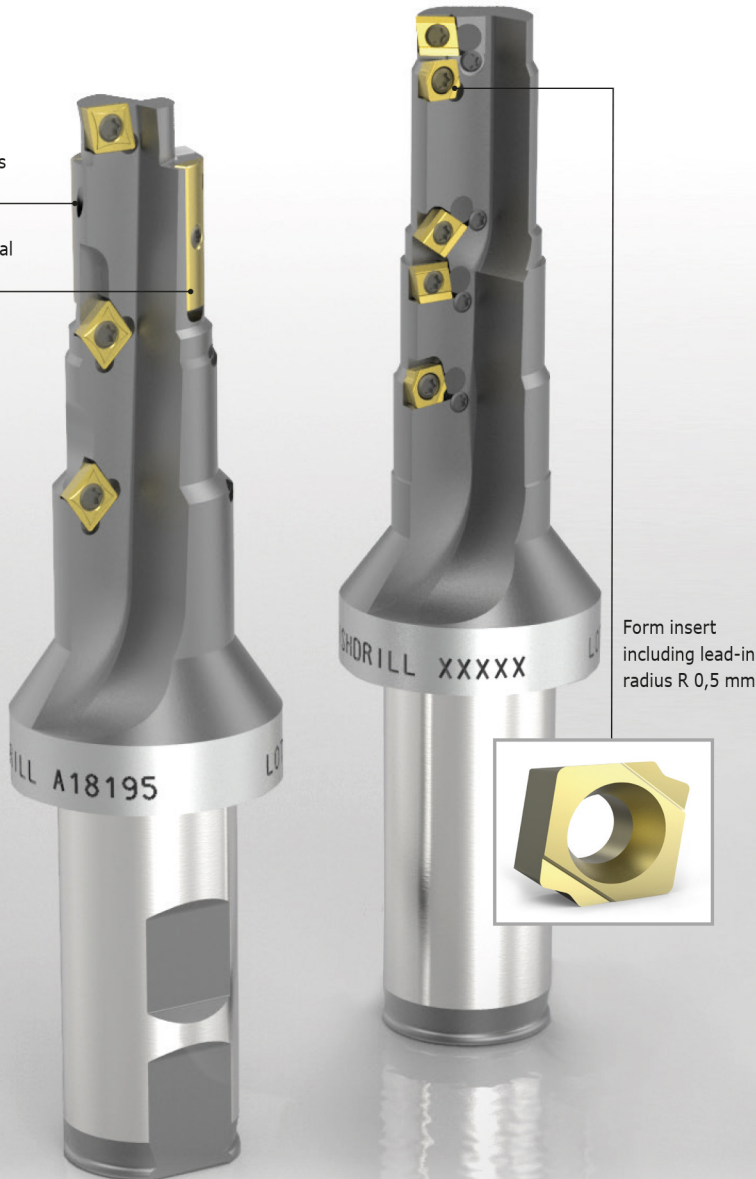

Sun T-11A

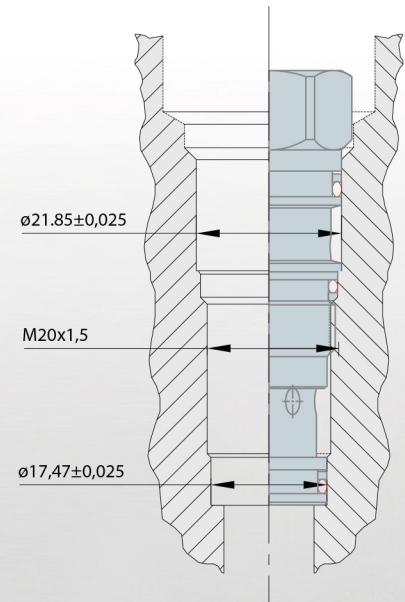

Advantages:

- One tool for blind and through bores
- Exchangeable inserts for various materials
- Ideal chip removal though improved coolant outlets and optimised body geometry
- Integrated guide pads for applications with interrupted cut or cross-holes
- Only one insert entire series 1 – internal radii possible through a form insert
- All components available from stock